

Product data sheet:

Electric height adjustable desk frame DM11

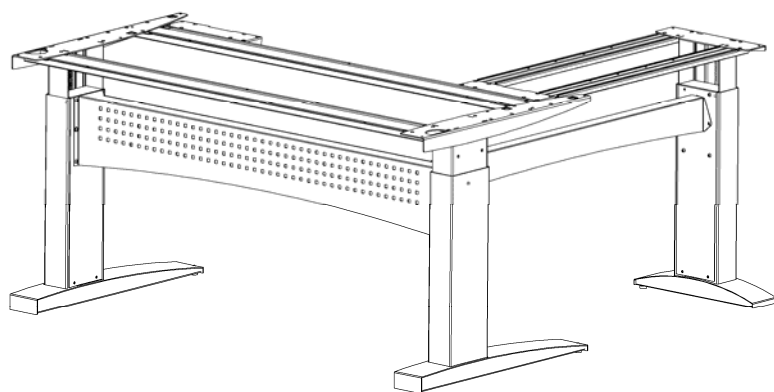
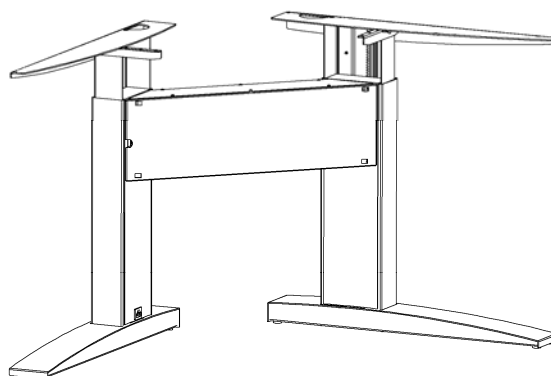
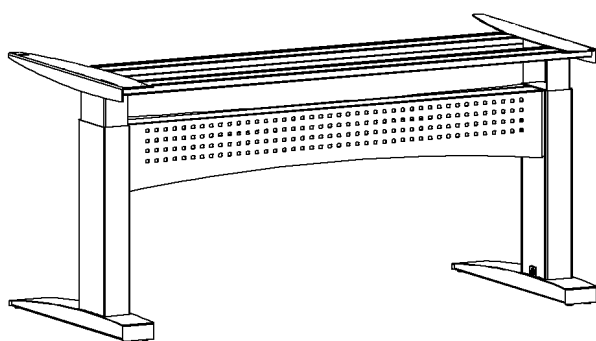
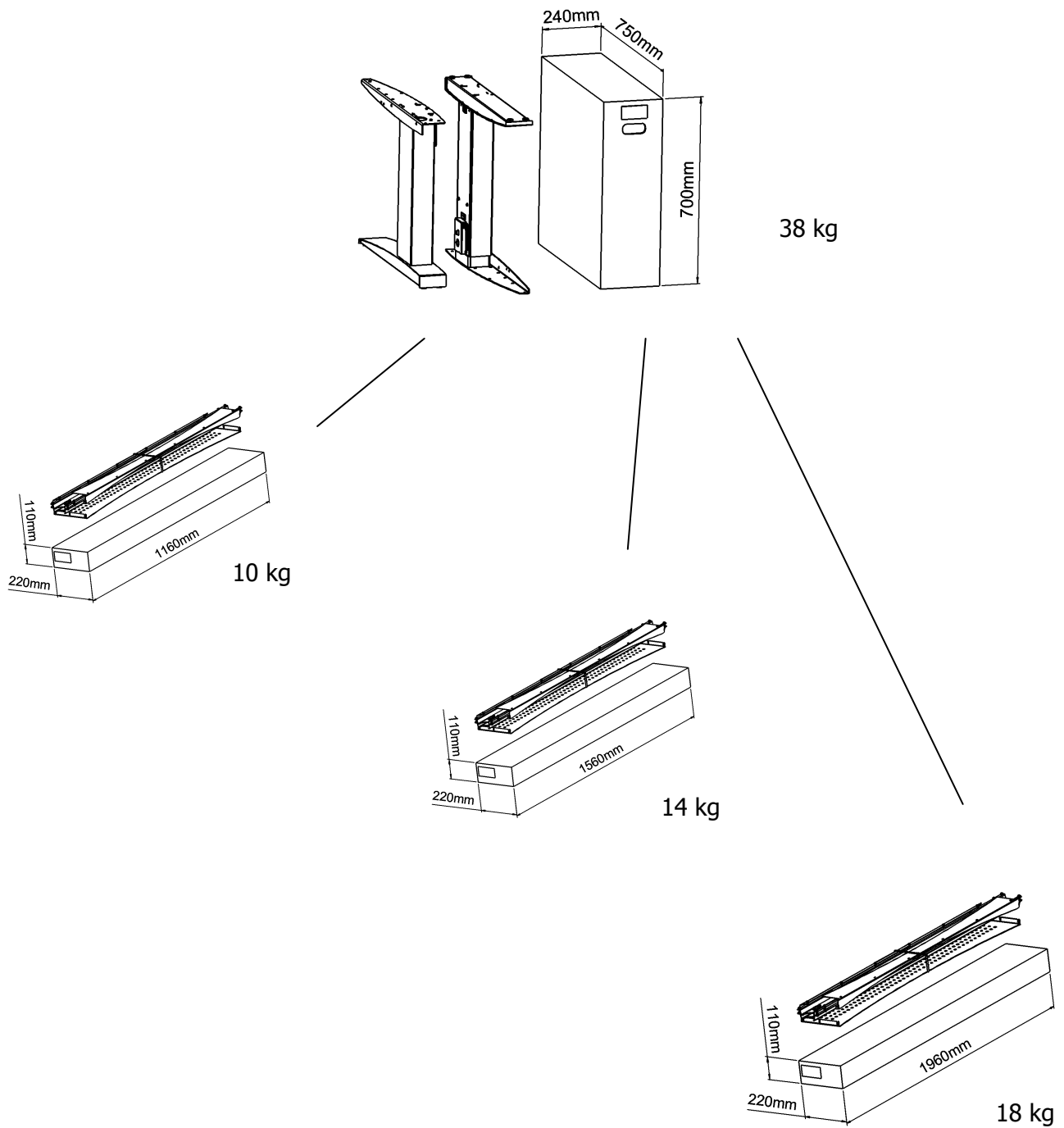

Table of contents

Packing details, 2 column straight frame	page 3
Main measures and specifications, 2 column straight frame	page 4
Tabletop drillings, 2 column straight frame	page 5
Packing details, 2 column corner frame	page 6
Main measures and specifications, 2 column corner frame	page 7
Tabletop drillings, 2 column corner frame	page 8
Packing details, 2 column corner frame	page 9
Main measures and specifications, 2 column corner frame	page 10
Tabletop drillings, 2 column corner frame	page 11
Assembly and use	page 12
Performance	page 13
Safety and tests	page 14
Component specifications	page 15

Packing details, 2 column straight frame



Main measures and specifications, 2 column straight frame

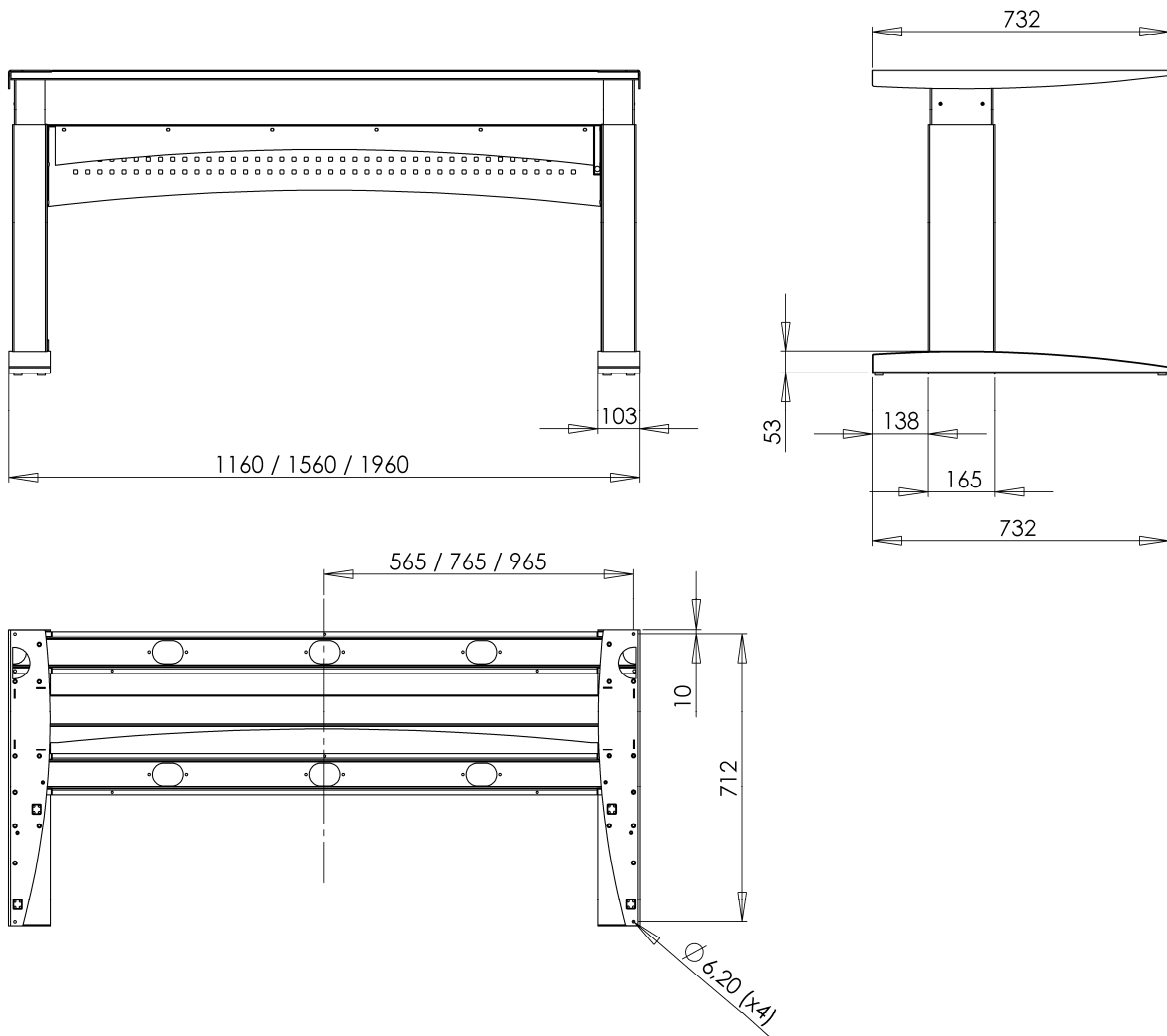

H (height), frame only	63 - 120cm
Lifting capacity, frame	150 kg
Speed	28 mm/sec

Tabletop drillings, 2 column straight frame

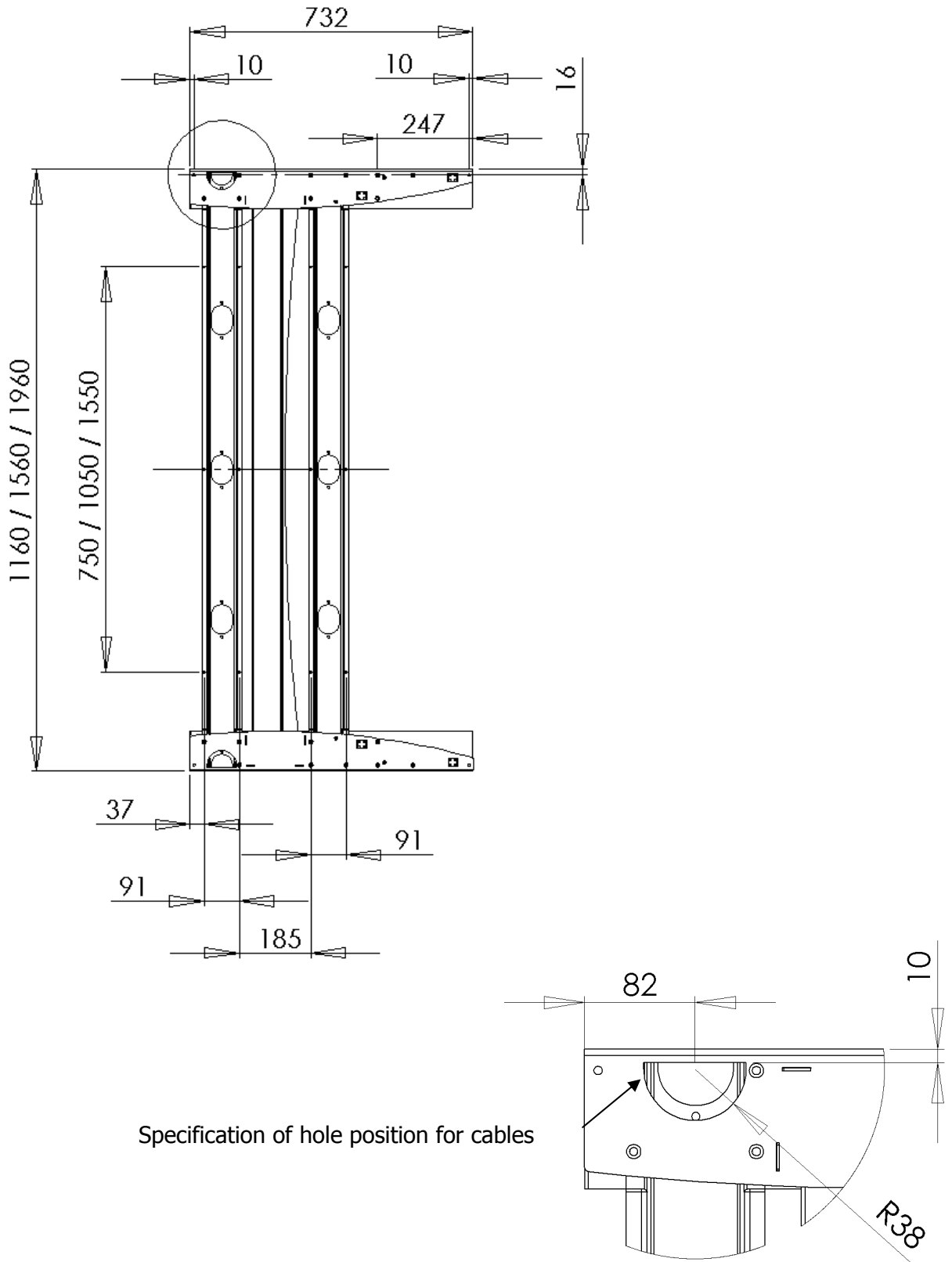

Packing details, 2 column corner frame

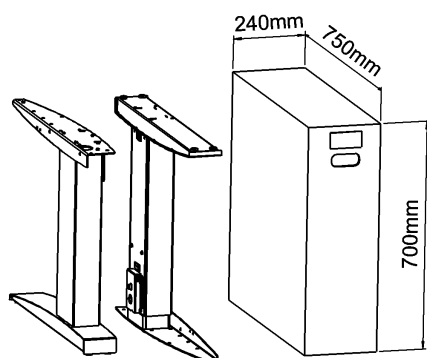

38 kg

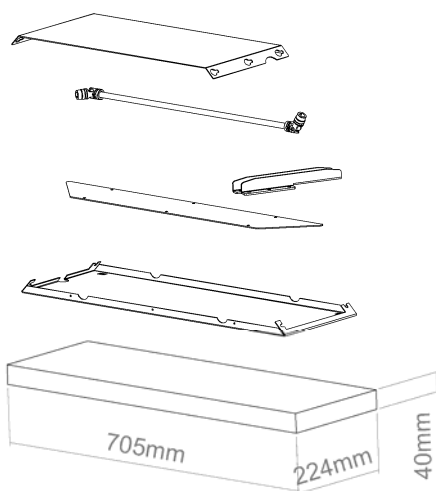

5 kg

Main measures and specifications, 2 column corner frame

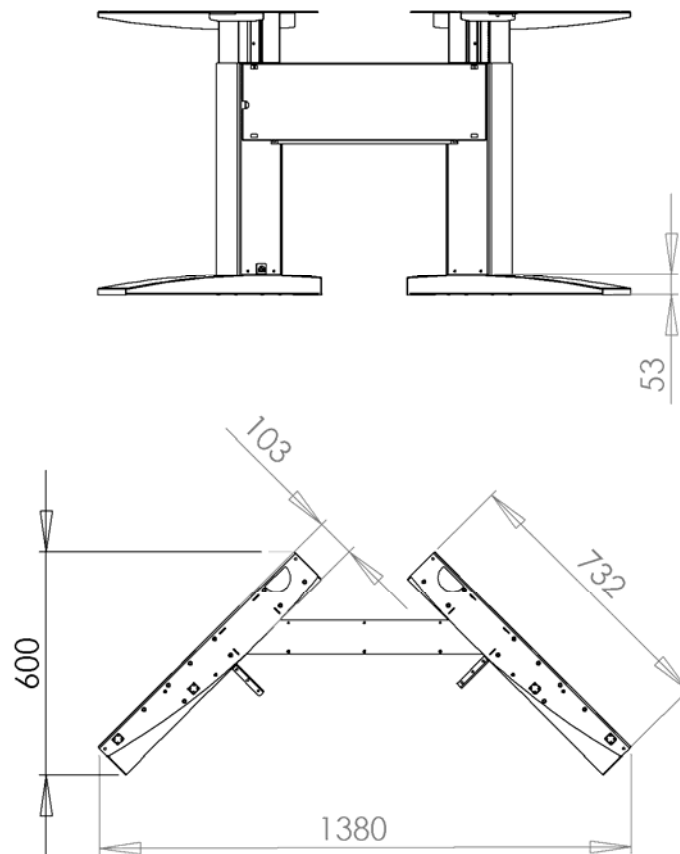

H (height), frame only	63 - 120cm
Lifting capacity, frame	100 kg
Speed	28 mm/sec

Tabletop drillings, 2 column corner frame

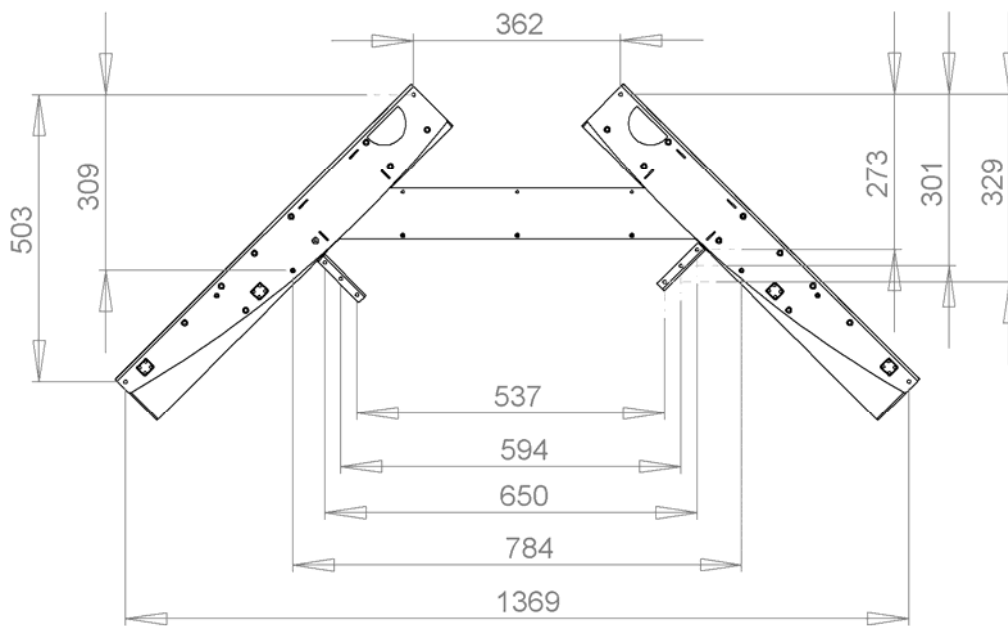

Packing details, 3 column corner frame

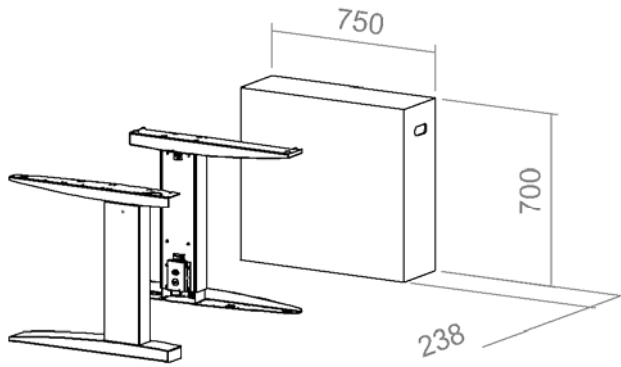

38 kg

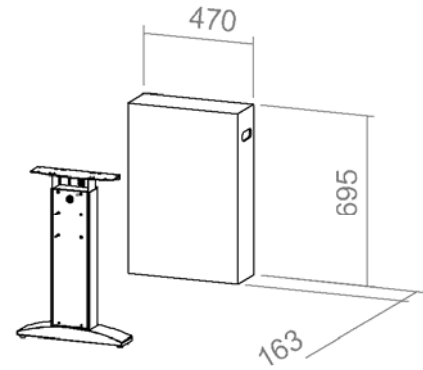

15 kg

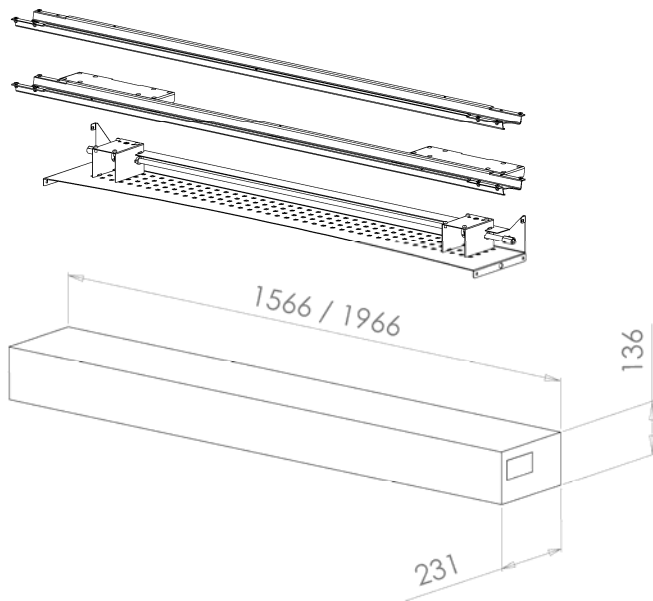

16 / 20 kg

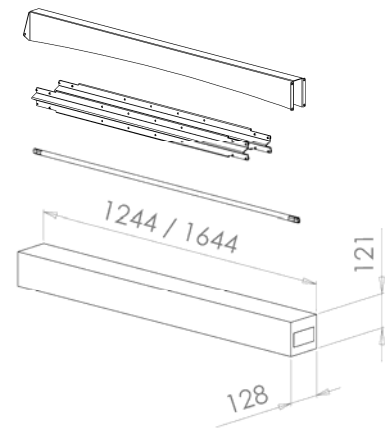

8 / 11 kg

Main measures and specifications, 3 column corner frame

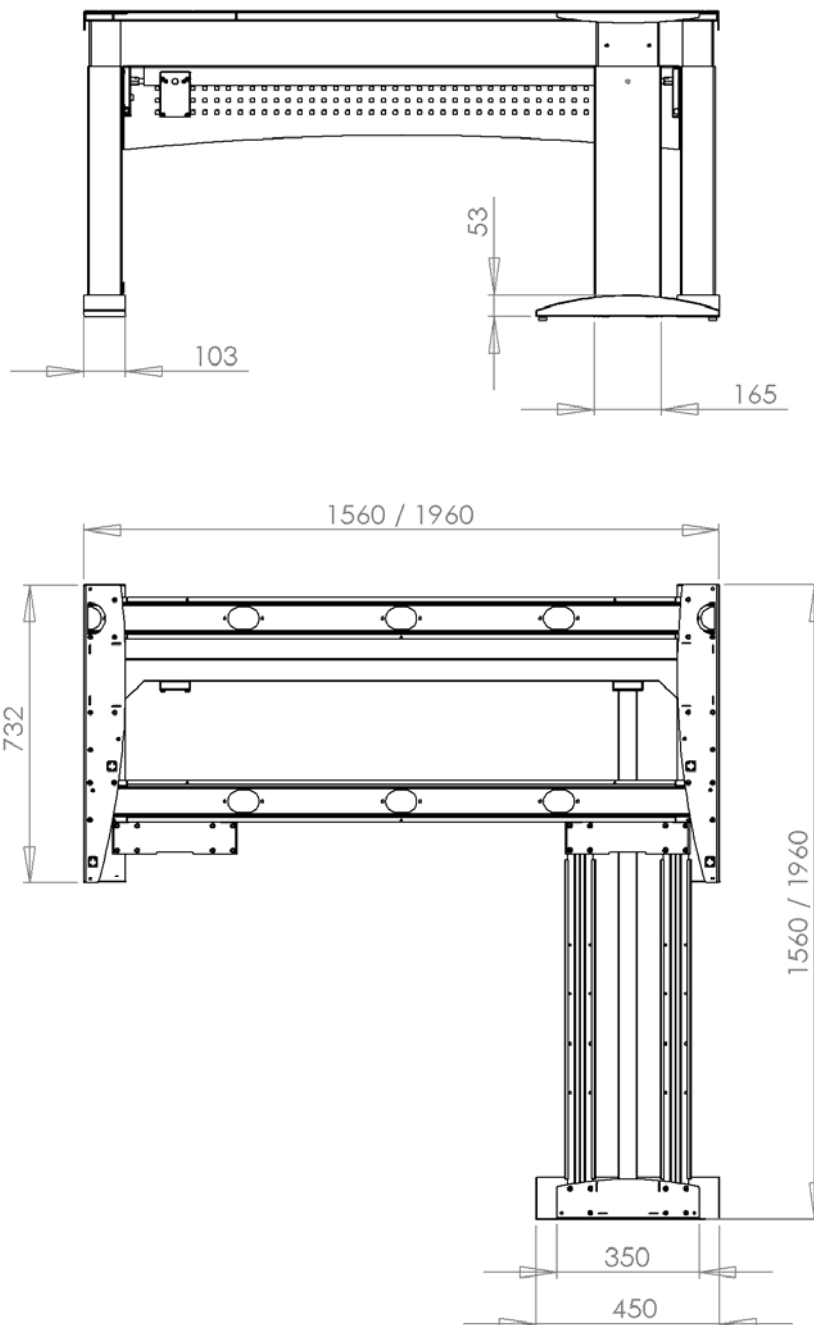

H (height), frame only	63 - 120cm
Lifting capacity, frame	150 kg
Speed	28 mm/sec

Tabletop drillings, 3 column corner frame

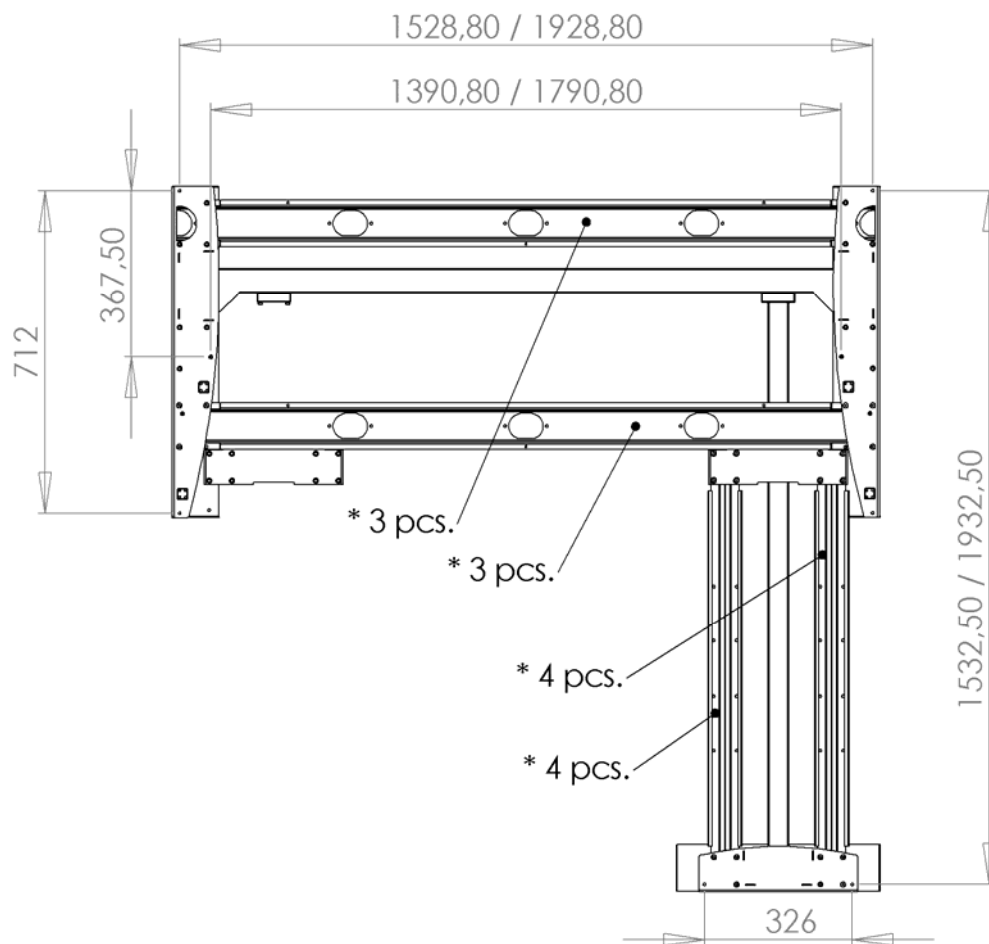

Specified drillings required for placing the tops correctly.

* marks showing additional needed fixing points.

Assembly and use

Along with all products a "Direction for assembly and use" is delivered. In this you will find a detailed description of the way of assembly, please find the sketch below coming from this instruction.

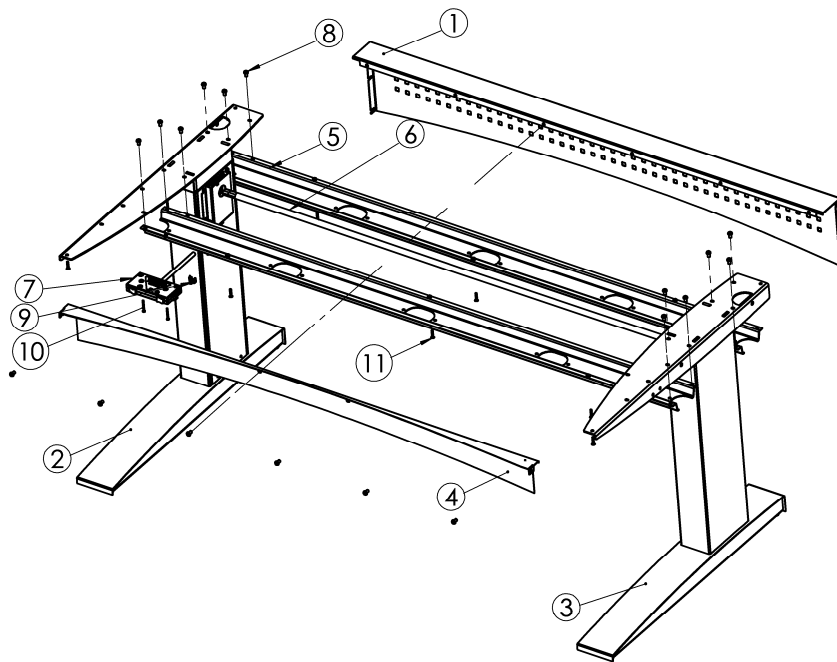

After the frame has been mounted the chosen tabletop is mounted and the operation unit will be possible to fix at the bottom side of the tabletop. This operation unit has two rocker switches.

With rocker switch A it is possible to connect or disconnect the AC voltage. If disconnected the standby consumption is 0 W !

With rocker switch B it is possible to move the tabletop up and down and can be stopped at all levels

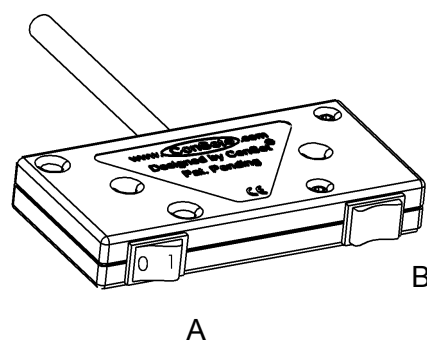

Performance, 2 column straight frame

Performance, load/speed

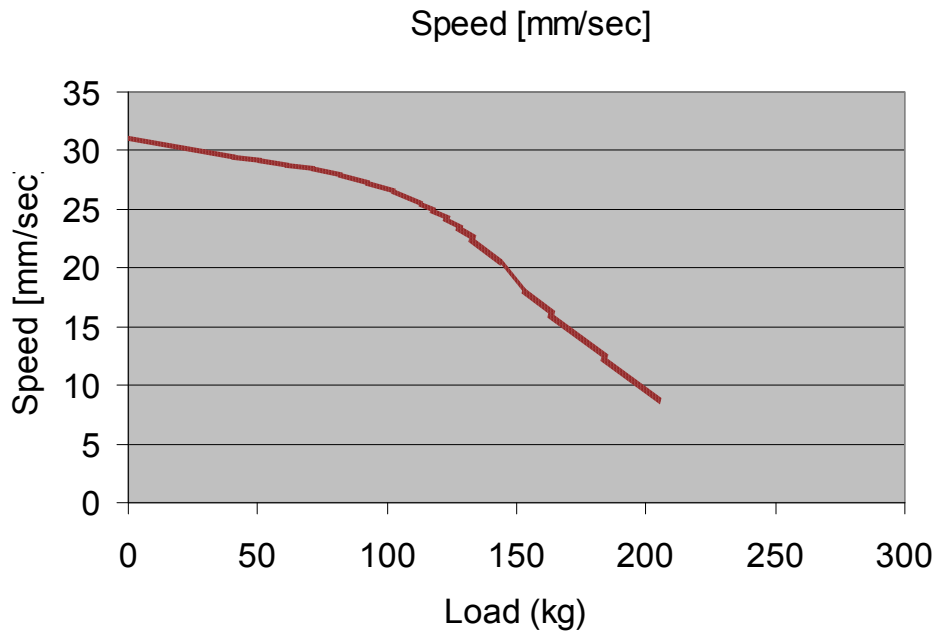

Rigidity in frame

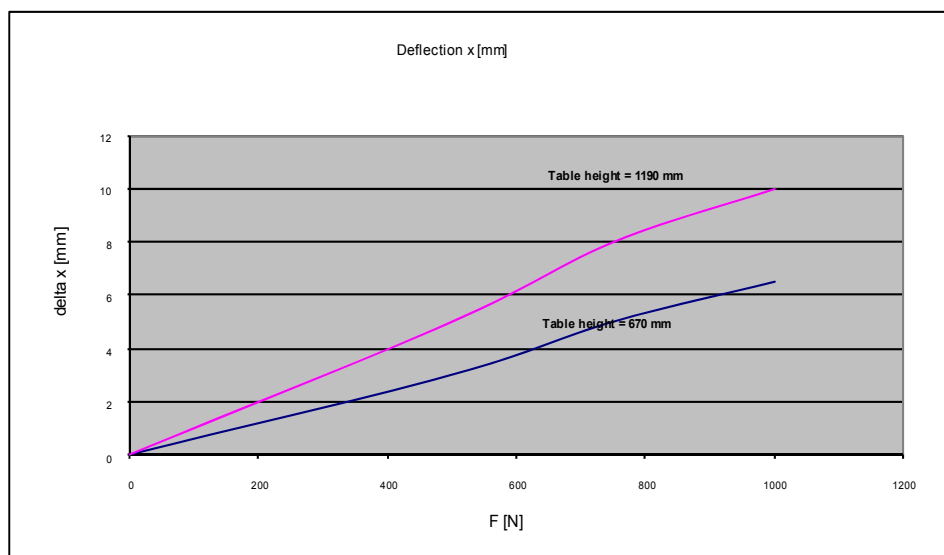
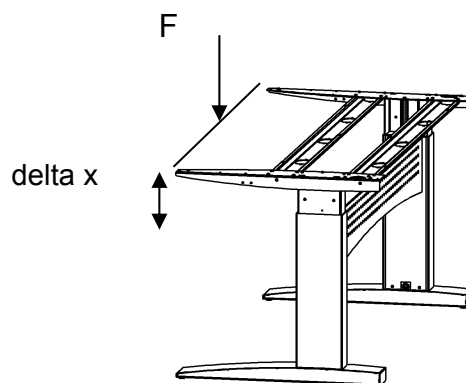

Product data sheet: Electric height adjustable desk frame DM11

Safety and tests

All products have been tested up against the following norms:

ISO/DIS 8019

DS/ISO 7172

The norms mention above is possible to find at the website in the section "Norms and approvals".

DECLARATION OF CONFORMITY

We hereby declare, under our sole responsibility that the following products:

- Sit and stand tables product type DM11

which are covered by this statement, are in conformity with the following standards and other normative documents::

- Counsel Directive 98/37/EF
- Counsel Directive 89/336/EØF with later changes
- Counsel Directive 73/23/EØF with later changes

With reference to the Machinery Directive (98/37/EF) please be aware:

- the sit and stand table is considered a machine and
- the sit and stand table may not be used until it has been assembled and installed according to the instructions."

Component specifications

Metal sheet parts: St 37-2

Gear parts: St 70-2

Gear motor: Bosch no. 0 390 257 685

Power supply: 100 W switch mode power supply
Consumption: 100 Watts; Standby: Max 0,9 Watts

Plastic components: PEHD, PA6

Surface treatment Visible metal parts powder coated in black, RAL 9004 or "alu" colour RAL 9006
Non visible metal parts are surface treated (e.g. zinc plated)